

## A New Control of Single-Stage Grid Connected Photovoltaic System

M. Najafi, M. Siah, R. Ebrahimi, M. Hoseynpoor

Bushehr Branch, Islamic Azad University, Bushehr, Iran.

---

**Abstract:** In this paper a new type of grid connected photovoltaic (PV) system with maximum power point tracking (MPPT) and reactive power simultaneous control system is presented. System has two controlling loops to obtain the maximum power from the PV array and also has reactive power control (RPC). In order to decrease the complexity, cost and the number of converters, a single-stage PV system is applied. Using RPC and MPPT controllers, reference current is calculated and the current with low THD (<5%) is injected to grid through adaptive predictive current control (APCC) and current controlled voltage source inverter (CCVSI). The operation of the system is classified in to two day and night modes. In day mode MPPT and RPC control is accomplished and in night mode RPC control is accomplished like STATCOM operation. Reactive power control is continuously performed correctly with appropriate speed in two inductive and capacitive modes in both day and night modes. Thus, system utilization factor (SUF) increases to 100% which is just 20% for common PV systems. Mathematical modeling of the system and the results of simulations in MATLAB/SIMULINK software are presented to investigate the correctness of the results.

**Key words:** Grid connected PV system, Maximum power point tracking, Reactive power control, Adaptive predictive current control, CCVSI.

---

### INTRODUCTION

In order to increase the efficiency of PV systems, the maximum power point tracking (MPPT) methods are studied and developed (Gounden *et al*, 2009). Some common methods are as follow: Perturbation and Observation (P&O), Incremental Conductance (Inc), Constant Voltage (CV), and Parasitic Capacitance (PC). Using neural network algorithms, hill climbing, fuzzy control, short current pulse, adaptive control and ANFIS are some new methods introduced recently (Gounden *et al*, 2009),( Wiodong and Dunford, 2004),( Patcharaprakiti *et al*, 2005). In most of these papers, the goal is just obtaining the maximum possible power of PV and injecting it to grid. In paper (Thongpron and Kirtikara, 2006) it is shown that, for low sun radiation, the system absorbs some reactive power. In some papers this issue is considered and an MPPT with unit power factor is presented (Casade *et al*, 2006),(Chen *et al*, 2004). Also, MPPT control application for nonlinear loads and using PV application as active filter are presented (Wu *et al*, 2005). In these papers PV systems are utilizable just in sunny days and in result they can not operate in cloudy days and during nights. This will lead to system utilization factor reduction, (SUF=20%). In paper (Hassaine *et al*, 2009) in addition to maximum power point tracking, it is possible to apply PV to compensate the current harmonics during day and reactive power during night. In this condition, the operation of PV system is just in proportion with the variations of the considered load and no control is accomplished on grid's required reactive power. In this paper, grid connected PV system with MPPT and reactive power control is studied. Using additional reactive power controller, PV system is utilized continuously in two inductive and capacitive modes. Thus, in day mode, system injects active power and controls the reactive power considering MPPT. In night mode, system controls the reactive power like STATCOM. Thus system utilization factor (SUF) increases from 20% to 100%. Also, in respect to the fast response and better dynamic, current controlled voltage source inverters are used (Kazmierkowski, 2009). Many control methods are presented for CCVSI and in this paper APCC because of its good operation and low current THD is used (Madadi *et al*, 2009).

Single-stage PV system is used because of its low complexity and cost. At the end, simulation results are presented using MATLAB/SIMULINK software.

---

**Corresponding Author:** M. Hoseynpoor, Bushehr Branch, Islamic Azad University, Bushehr, Iran.

### MATERIALS AND METHODS

The proposed system is consisted of three main parts: mathematical model of PV cell, maximum power point tracking algorithm and structure and control of grid connected PV system. The last part consists of three sections; system structure, adaptive predictive current controller, power control in grid connected PV system. These parts have discussed and finally the simulation results have been introduced.

#### I. Mathematical Model of PV Cell:

The equivalent circuit of PV is shown in Fig. 1. In PV equivalent circuit,  $I$  is mentioned as a function of the voltage of PV array as follow (Rauschenbach, 1980):

$$I = I_{SC} \left\{ 1 - k_1 \left[ \exp((k_2 \cdot V^m) - 1) \right] \right\} \quad (1)$$

$$K_2 = \frac{K_4}{V_{OC}^m} \quad (2)$$

$$K_3 = \ln \left[ \frac{I_{SC}(1 + K_1 - I_{mpp})}{K_1 \cdot I_{SC}} \right] \quad (3)$$

$$K_4 = \ln \left( \frac{1 + K_1}{K_1} \right) \quad (4)$$

$$m = \frac{\ln \left( \frac{K_3 / K_4}{V_{mpp} / V_{OC}} \right)}{\ln \left( \frac{K_3 / K_4}{V_{mpp} / V_{OC}} \right)} \quad (5)$$

where  $I_{mpp}$  is the current in maximum power point,  $V_{mpp}$  is the voltage in maximum power point,  $I_{SC}$  is the short circuit current,  $V_{OC}$  is the open circuit voltage and  $K_1=0.01175$ . Usually the manufacturers examine and introduce  $I_{SC}$ ,  $V_{OC}$ ,  $V_{mpp}$  and  $I_{mpp}$  under standard conditions (STC). It should be considered that equation (1) is useful just for constant sun radiation ratio ( $G$ ) and constant cell temperature ( $T_C$ ). By variation of sun radiation ratio and cell temperature, the cell parameters will be changed as follow:

$$\Delta I = \alpha_{STC} \left[ \frac{G}{G_{STC}} \right] \Delta T_C + \left[ \frac{G}{G_{STC}} - 1 \right] I_{SC.STC} \quad (6)$$

$$\Delta V = -\beta_{OCT} \cdot \Delta T_C - R_S \cdot \Delta I \quad (7)$$

$R_S$  is calculated through the PV array's  $I$ - $V$  characteristics diagram in constant temperature (presentable by manufacturer).

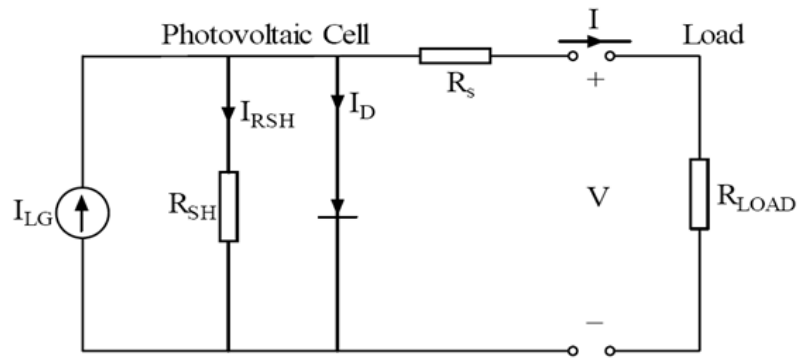

Fig. 1: Equivalent circuit of PV.

Relations (1)-(7) are simulated by MATLAB/SIMULINK and the results are shown in Fig. 2 for sun radiation ratio variations in constant temperature. Obviously, for the radiation ratio variation, voltage and current outputs will be changed in compare with the standard conditions ( $G=1000 \text{ W/m}^2$ ).

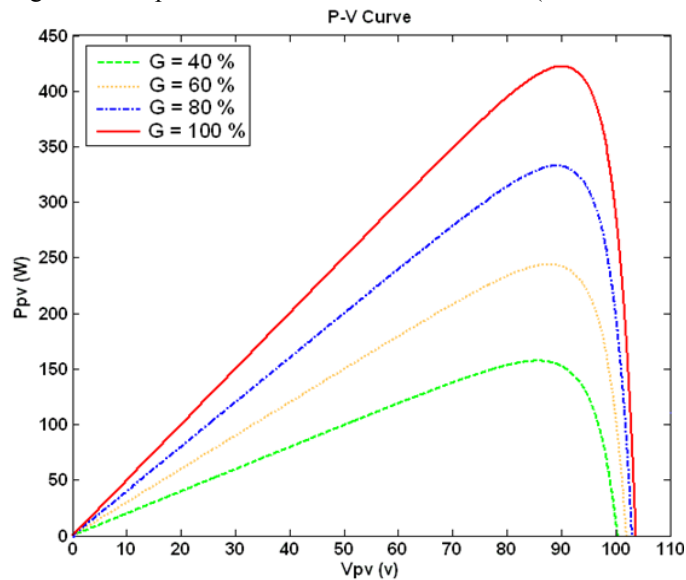

Fig. 2: P-V curve of PV array.

**II. Maximum Power Point Tracking Algorithm:**

Considering the simulation results mentioned in previous section, it is obvious that the power generated in PV depends on the sun radiation ratio, cell temperature and cell voltage. In respect to Fig. 2, for constant radiation and temperature, the power is maximum on an specific point. The aim is achieving this maximum point to maximize the efficiency of system. MPPT algorithms are applied to module operation at this specific point. Among these methods, Inc method shows fast response and high dynamic and the experimental results show that the efficiency of this method is more than the efficiency of other common methods. Also, Inc algorithm can track the maximum power point, through recognizing the maximum power point achieving time, shedding the oscillations around the maximum power point and clearing the applied variations (Sera *et al*, 2006). Thus in this paper Inc method is used to extract the maximum power of PV. In Inc method, the conductance deviation ( $di/dv$ ) is applied to determine the sign of  $dp/dv$ . It can be shown that in MPPT,  $dp/dv = -i/v$ . So, MPPT is obtained through this. In Fig. 3, the Inc method related flowchart is shown.

**III. Structure and Control of Grid Connected PV System:**

**III.A. System Structure:**

PV systems have either single-stage or double-stage structures. In double-stage PV system, a DC/DC converter is applied to obtain the maximum power and MPPT control, and finally power is injected to grid through an inverter. Single-stage PV systems do not require DC/DC converter and MPPT control is

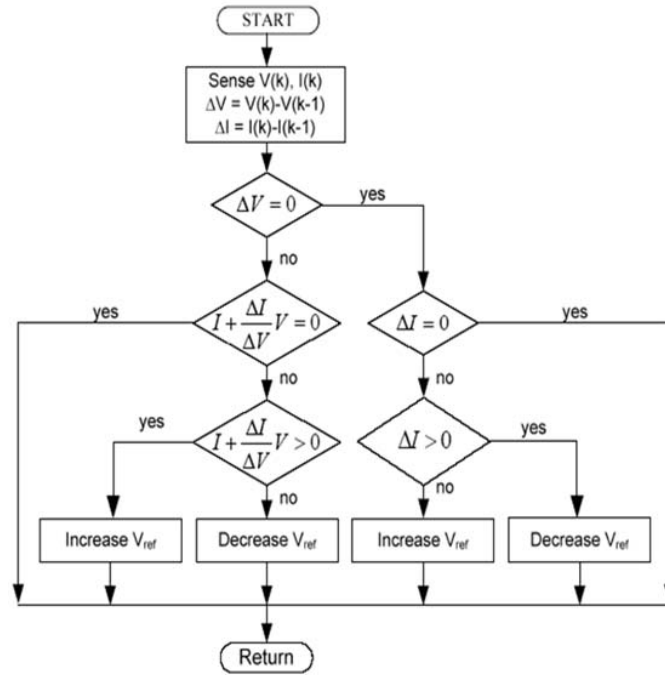

**Fig. 3:** Flowchart of Inc algorithm.

accomplished through inverter. Low cost, economic characteristics and high efficiency are some of the advantages of these systems because of their less converter comprised structure. In this paper, single-stage structure is applied. In fig. 4 the general structure of the grid connected PV system is shown. Generated electrical energy is transferred to grid through PV modules using single phase CCVSI. MPPT controller is applied to extract the maximum power of module during the day light and RPC is applied to exchange reactive power with the grid in both day and night modes. Using RPC, the reference current with low THD and appropriate speed is injected to grid.

**III.B. Adaptive Predictive Current Controller:**

In predictive current controller, required inverter voltages are calculated to close the load current value to reference current value. This method has the minimum current fault, constant switching frequency and resists against the parameter variations and is easily programmable in DSP microcontroller. In respect to fig. 4 and assuming that the grid voltage variations are linear during switching period  $[n, n+1]$ , the average of inverter output ( $V_{op-av}[n]$ ) is calculated as follow to equalize the load current ( $I_{load}$ ) at  $[n+1]$  moment with reference current ( $I_{ref}[n+1]$ ) [10]:

$$I_{load}[n] = I_{load}[n-1] + \frac{T_{period}}{L} \times \left( V_{op-av}[n-1] - \frac{3V_{grid}[n-1] - V_{grid}[n-2]}{2} \right) \tag{8}$$

$$V_{op-av}[n] = \left( 1.5 + \frac{L_m}{T_{period}L} \right) V_{grid}[n] - 0.5V_{grid}[n-1] - \frac{L_m}{L} (V_{op-av}[n-1] + \frac{L}{T_{period}} I_{ref}[n+1] - \frac{L_m}{T_{period}} I_{load}[n-1]) \tag{9}$$

where  $L$  is the filter inductance,  $T_{period}$  is switching period time;  $L_m$  is the inductance value in microcontroller. After calculating the average of the output voltage, the aim is creating this voltage in inverter output for the next switching period. In order to achieve this, space vector modulation (SVM) is applied.

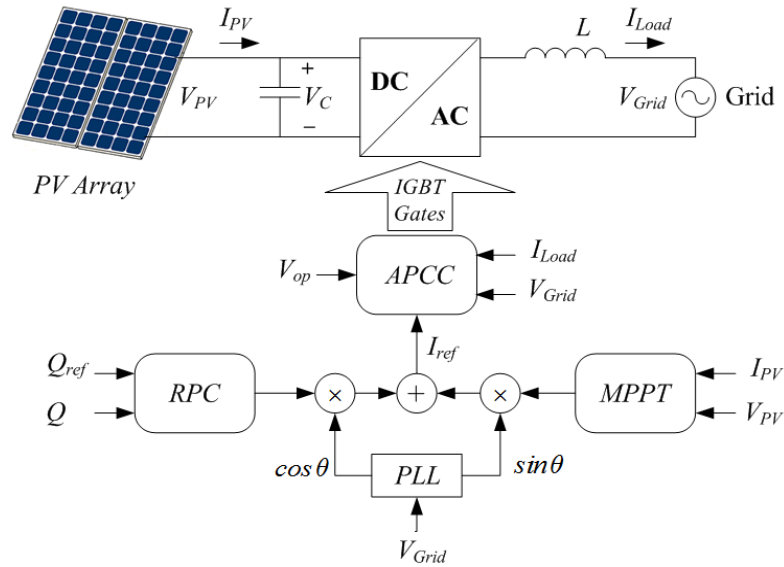

**Fig. 4:** Configuration and control system of proposed grid connected PV system.

**III.C. Power Control in Grid Connected PV System:**

In many instances, PV systems are used as active power generators considering MPPT, where the maximum power is injected to grid. As sun radiation decreases, the maximum power decreases and in fact the maximum capacity of system is not in use. Also at nights, grid connected PV system cannot generate active power. In all PV systems a DC capacitor is applied to stabilize the DC link voltage. By switching, regulating the voltage of capacitor and the phase of output current, the reactive power can be injected or absorbed. Under this condition, the operation of system is like the operation of STATCOM which is a reactive power controller. The new idea presented here applies PV as a reactive power controller considering MPPT during all times of day. So, operational mode is classified into two day and night modes.

In day mode, active and reactive powers are controlled independently using CCVSI. According to fig. 4, the system has two reactive power and MPPT controlling loops. MPPT controller computes the active component of reference current ( $I_{dref}$ ) using PV input current ( $I_{pv}$ ) and voltage ( $V_{pv}$ ). RPC controller generates the reactive component of reference current ( $I_{qref}$ ) using PI controller by comparing the measured value of reactive power with its reference value ( $Q_{ref}$ ). In order to synchronize the generated inverter voltage with the grid voltage, a phase locked loop (PLL) is used. Finally, APCC controller calculates the switching time and inverter output voltage and applies it to IGBT switches by SVM method. In night mode, reference current has just reactive component which is determined and regulated by RPC controller. Operation characteristic is like STATCOM which can control reactive power continuously in both day and night modes.

**RESULTS AND DISCUSSION**

In order to study the system's characteristics and efficiency, and also to study the presented MPPT algorithm, the system is simulated through MATLAB/SIMULINK software in both day and night modes. The characteristics of the system are brought in table [1].

**Table 1:** Characteristics and parameters of the grid connected PV system.

Grid Parameters	Values	Grid Parameters	Values
L	3 mH	$V_{grid}$	220V <sub>m</sub>
$V_{mppt}$	252 v	$P_n$	4 kw
$I_{mppt}$	21.96A	$f_n$	50HZ
$V_{oc}$	315 v	DC link Capacitor	2000µF
$I_{sc}$	23.22 A	Cell Type	MSX60

Simulation of the system in day mode is shown in Figs. 6 and 7. In order to study the dynamic behavior of system, sun radiation ratio is considered to vary from  $G=700 \text{ W/m}^2$  to  $G=1000 \text{ W/m}^2$ . As it is shown, active and reactive powers are independently controllable and system operates in MPPT during exchanging specified reactive power with grid.

In Fig. 6, the aim is extracting the maximum power of PV and obtaining 500var reactive power from the grid (inductive mode). In Fig. 6-a, grid injected active power is shown and the reactive power is presented in fig 6-b. As it is shown, active and reactive powers are independently controllable and the system provides the determined required reactive power correctly with appropriate speed and low THD. In fig 6-c, the output current of inverter and grid voltage are shown, where the current lags the voltage. For  $G=700 \text{ W/m}^2$ , THD of current is 3.6% and for  $G=1000 \text{ W/m}^2$ , decreases to 2.5%.

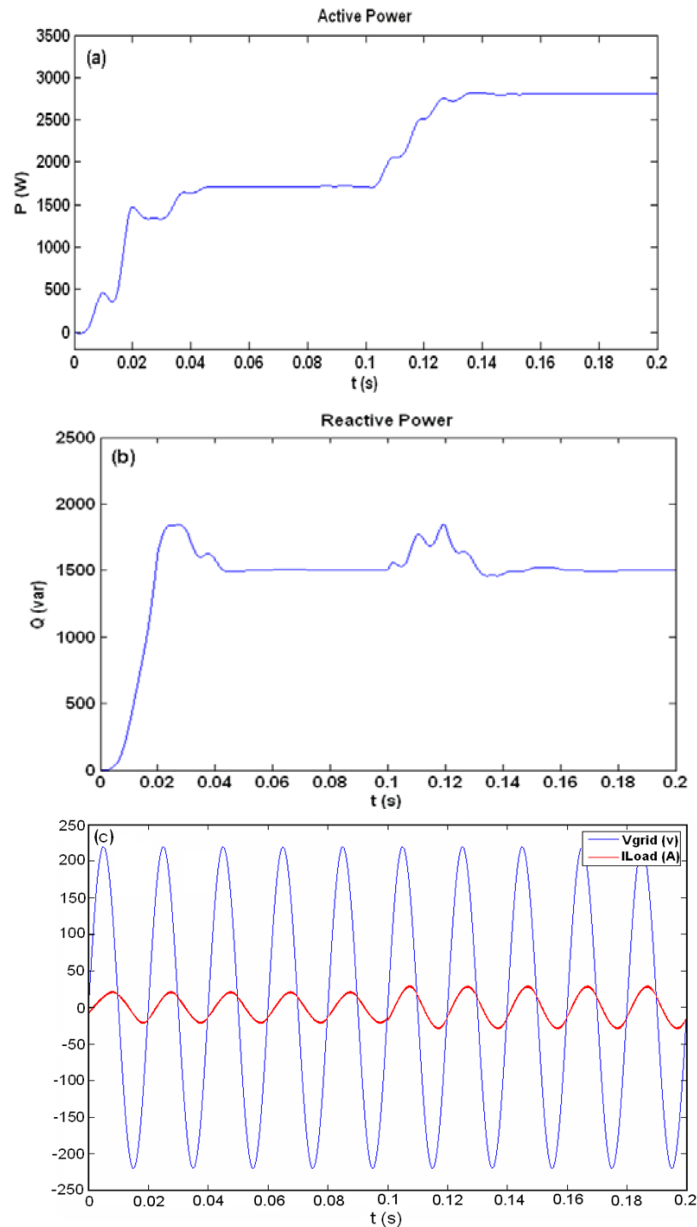

**Fig. 6:** System simulation results for sun radiation variation with applying MPPT and  $Q_{ref}=1500var$ .

In fig. 7, the results are shown for  $Q=1500\text{var}$  (capacitive mode).

In fig. 8 system is simulated in night mode. The results are shown for  $Q_{ref}$  variation from  $+3000\text{var}$  (inductive mode) to  $-3000\text{var}$  (capacitive mode) in  $t=1\text{s}$ . In fig. 8-a, the reactive power is shown which is zero. As shown in fig. 8-b, the system initially absorbs the power and after  $t=1\text{s}$ , injects reactive power to grid. As it is shown, it is possible to continuously control the reactive power during night in both inductive and capacitive modes by controlling capacitor voltage.

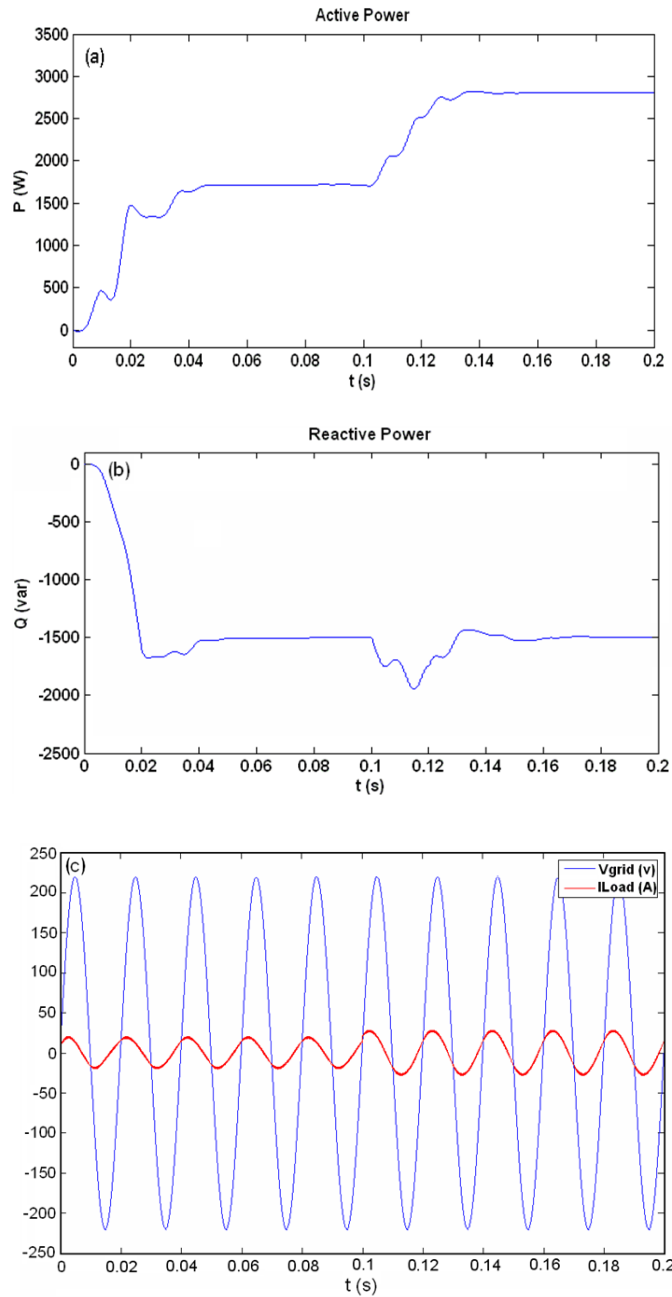

**Fig. 7:** System simulation results for sun radiation variation with applying MPPT and for and  $Q_{ref} = -1500\text{var}$ .

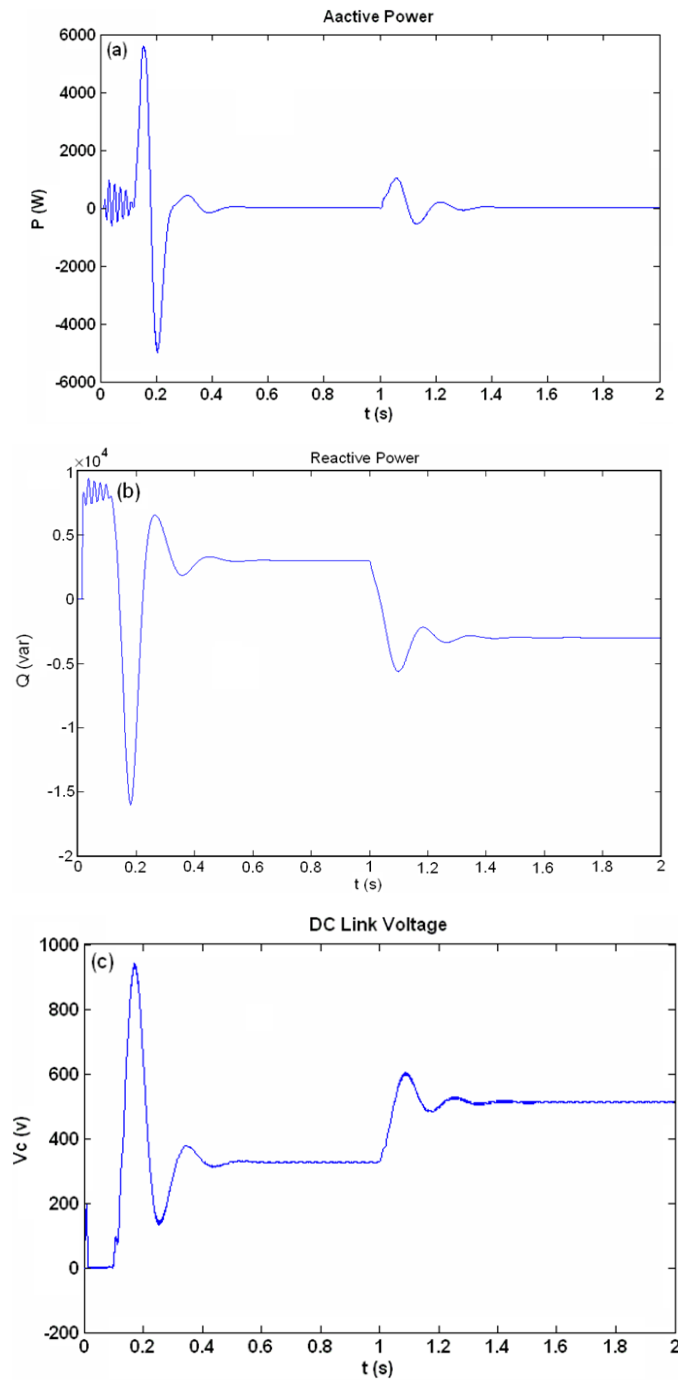

**Fig. 8:** System simulation results for night mode. a) active power, b) reactive power, c) DC link voltage.

**Conclusion:**

In this paper a grid connected PV system with MPPT and RPC methods is studied. Described system has two independent control loops to control MPPT and reactive power. Reference current is calculated and injected to grid with low THD through APCC method. In order to decrease the complexity, cost and the number of inverters the single-stage PV is used which increases the efficiency. The system has two operation modes; day and night. In day mode, MPPT and RPC are accomplished and just reactive power control method is accomplished in night mode. Reactive power in both modes is continuously controllable and is able to operate with appropriate speed in both inductive and capacitive modes. Thus, the system utilization factor



increases to 100% which is 20% for common PV systems. The mentioned system is studied and simulated by MATLAB/SIMULINK software and simulation results show that the system operates correctly in both day and night modes with low output current THD.

## REFERENCES

- Casade. D., G. Grandi and C. Rossi, 2006. Single-phase single-stage photovoltaic generation system based on a ripple correlation control maximum power point tracking. *IEEE Transaction on Energy Conversion*, 21(2): 562-568.
- Chen Y.M., Y.C. Liu and Y.W Feng, 2004. Multi-input converter with power factor correction, maximum power point tracking and ripple-free input currents. *IEEE Transactions on Power Electronics*, 19(3): 631-639.
- Gounden N.A., Sabitha Ann Peter, Himaja Nallandula and S. Krithiga 2009. Fuzzy logic controller with MPPT using line-commutated inverter for three-phase grid-connected photovoltaic systems. *Renewable Energy*, 34(3): 909-915.
- Hassaine. L., E. Olias, J. Quintero and M. Haddadi, 2009. Digital power factor control and reactive power regulation for grid-connected photovoltaic inverter. *Renewable Energy*, 34(1): 315-321.
- Kazmierkowski. M.P., 1998. Current Control Techniques for Three-Phase Voltage-Source PWM Converters: A Survey. *IEEE Transaction on Industrial Electronics*, 45: 691-701.
- Madadi. H., B. Yu, I.A. Gadoura. L. Chang and M. Gharibi, 2009. A Novel DSP-based Current-Controlled PWM Strategy for Single Phase Grid Connected Inverter. *IEEE Transactions on Power Electronics*, 21(4): 985-993.
- Patcharaprakiti. N., S. Premrudeepreechacharn and Y. Sriuthaisiriwong, 2005. Maximum power point tracking using adaptive fuzzy logic control for grid-connected photovoltaic system. *Renewable Energy*, 30(11): 372-377.
- Rauschenbach, S., 1980. *Solar Cell Array Design Handbook*. Van Nostrand Reinhold company.
- Sera, D., T. Kerekes, R. Teodorescu and F. Blaabjerg, 2006. Improved MPPT Algorithms for Rapidly Changing Environmental Conditions. *Power Electronics and Motion Control Conference*, 55(7): 2629-2637.
- Thongpron, J. and K. Kirtikara, 2006. Effects of low radiation on the power quality of a distributed PV-grid connected system. *Journal of Solar Energy Materials and Solar Cells*, 90(15):
- Wiodong, X. and W.G. Dunford, 2004. A modified adaptive hill climbing MPPT method for photovoltaic power systems. *Power Electronics Specialists Conference*, 3: 1957-1963.
- Wu, T.F., C.L. Shen and H.S. Nei, 2005. A 1 $\phi$ 3W inverter with grid connection and active power filtering based on nonlinear programming and fast-zero-phase detection algorithm. *IEEE Transactions on power Electronics*, 20(1): 218-226.