

## A Simple Method to Control of Variable Speed Wind Generation System Coupled with Squirrel Cage Induction Generator

M. Najafi, M. Siahi, R. Ebrahimi, M. Hoseynpoor

Bushehr Branch, Islamic Azad University, Bushehr, Iran.

---

**Abstract:** In this paper maximum power control of wind turbine and induction generator connected with two back to back voltage source converters to grid are studied. Machine currents are controlled by indirect vector control method. In this method, generator side converter controls the maximum excitation (air gap flux) by machine's d-axis current and controls generator torque by machine's q-axis current. Induction generator speed is controlled by tip speed ratio (TSR) upon the wind speed variations in order to generate the maximum output power. Grid side converter regulates the DC link voltage and injective active power by d-axis current and regulates the injective reactive power by q-axis current using simple control method P-Q. Simulation results show that the proposed method operates correctly.

**Key words:** Maximum power control, Variable speed wind system, Squirrel cage induction generator, Vector control

---

### INTRODUCTION

Nowadays, among the renewable energy sources, wind systems are more economic in compare with the others (Weisser and Garcia, 2005). Variable speed wind systems deliver 20% to 30% more energy than the constant power systems. Also they reduce the power oscillation and optimize the reactive power presentation (Kim and Kim, 2007). In order to get the maximum power in different wind speeds, turbine speed should be able to vary in a great range. Selecting the type of generator depends on different elements such as kind of function, machine characteristics, maintenance and price. Achieving the maximum power under direct connection of induction generator to the grid in constant frequency and voltage condition is impossible, because if induction generator is connected to grid directly there won't be the possibility of a great speed variation between the synchronous speed and the speed in proportion with the maximum torque.

Doubly fed induction generator (DFIG) has not the ability to operate in great range of speed variations despite it is greatly used in wind systems. Permanent magnet synchronous generators (PMSG) are too expensive to be used in high rate powers.

Squirrel cage induction machines, are used greatly in industrial purposes because of their low cost, robustness and easy maintenance. These advantages introduce this machine as an appropriate choice to be applied in variable speed wind systems (Senjyu *et al*, 2006).

The power created by the wind is related to the 3rd power of wind speed. Applying power electronics converters to transfer induction generator's power to grid by the possibility of speed variation in a great range, is preferred because of their great advantages. Wind turbines with power electronics circuits in the 4 to 5 MW power range will be applied greatly in near future (Badrul *et al*, 2006). The method applied to control the speed and power of synchronous and induction generators are now applied to the wind energy converting systems (WECS) to obtain the maximum power of wind turbine (Surgevil and Akpınar, 2005). Back to back converter is an appropriate choice for squirrel cage induction generator used in wind system (Pena *et al*, 2002). Fig. 1 shows wind power generation system connected through two back to back converters to grid.

Vector control methods are used to separately control the torque and machine flux [7]. In this paper indirect vector control method is used to control generator where d-axis current controls the flux and q-axis current controls the machine speed. Also machine speed is regulated in a way that as maximum energy as possible will be obtained. In order to connect the system to the grid, two back to back power electronics converters are used. In order to control the grid side converter, P and Q, injected to grid are calculated in d-q axis and required control to inject the desired valued is applied by PI controllers. Simulation results are presented by MATLAB/SIMULINK software. Simulation results confirm the back to back converter's appropriate operation and also confirm the operation of power injection to grid applying induction generator.

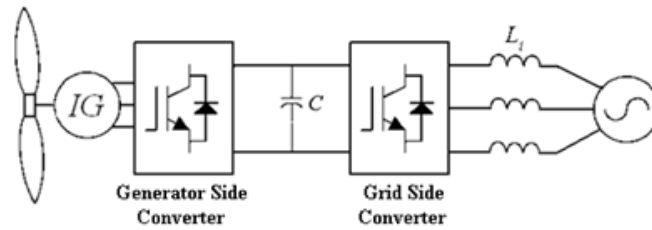

**Fig. 1:** Connection of wind power generation system to grid through back to back inverters.

**Proposed System:**

The proposed system is consisted of five main parts: Wind model, Wind Turbine, Turbine Maximum Power Control, Induction generator, Generator side converter control and grid side converter control. These parts have discussed and finally the simulation results have been introduced.

**1. Wind Model:**

The model applied for this simulation is composed of three components and is described as follow [2]:

$$V_{WIND} = V_{BASE} + V_{GUST} + V_{RAMP} \tag{1}$$

where  $V_{BASE}$  is the main component,  $V_{GUST}$  is the gust component and  $V_{RAMP}$  is the ramp component. The main component is a constant speed. Ramp component can be expressed by a sinusoidal function which is considered as a composition of several different sinusoidal functions and gust component is considered as storm and sudden wind.

**2. Wind Turbine:**

The torque generated by wind blow is described by the following relations:

$$\lambda = \frac{\omega_M R}{V_{WIND}} \tag{2}$$

$$P_M = \frac{1}{2} \rho \pi R^2 C_p V_{WIND}^3 \tag{3}$$

$$T_M = \frac{P_M}{\omega_M} = \frac{1}{2} \rho \pi R^5 C_p \frac{\omega_M^3}{\lambda^3} \tag{4}$$

where  $V_{WIND}$  is wind speed,  $R$  is the blades radius,  $P$  is the air density,  $\omega_M$  is rotor angular speed and  $\lambda$  is the tip speed ratio (TSR),  $C_p$  is the power conversion factor which can be defined as turbine power in proportion with wind power and is related to blades aerodynamic characteristics. Resulted mechanical torque is applied as the input torque to the wind generator and makes generator to operate. Power conversion factor is expressed as the function of tip speed ratio  $\lambda$  as follow:

$$C_p = (0.44 - 0.0167\beta) \sin \frac{\pi(\lambda - 2)}{13 - 0.3\beta} - 0.00184(\lambda - 2)\beta \tag{5}$$

where  $\beta$  is blade's pitch angle. For a turbine with constant pitch,  $\beta$  is considered as a constant value, Fig. 2 is  $C_p$  variations in terms of  $\lambda$  for different  $\beta$  values. In this paper  $\beta$  is considered zero where the  $C_p$  value would be 0.48 then.

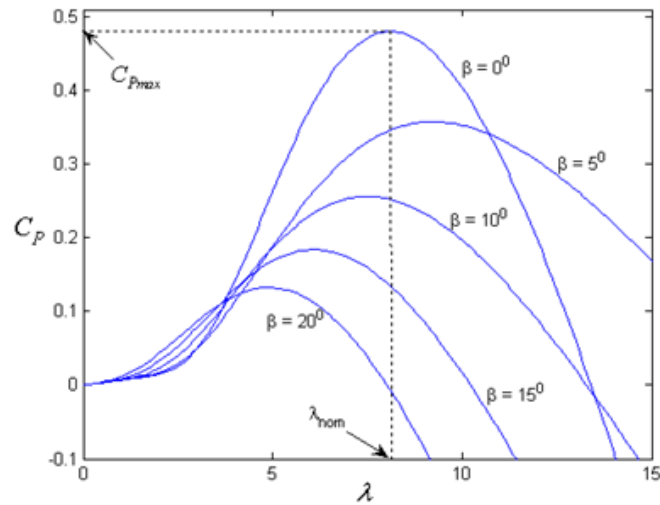

Fig. 2:  $C_p$  in terms of  $\lambda$  for different  $\beta$  values.

Table 1 shows the wind turbine parameters values applied in simulation.

Table 1: Wind Turbine Parameters

Rated Power	15 kW
Blade radius	5.5 m
Nominal wind speed	12 m/s
Minimum wind speed	4 m/s
Maximum wind speed	18 m/s
Blade pitch angle	0

3. Turbine Maximum Power Control:

Fig. 3 shows the relation between turbine output power and its speed in terms of different wind speeds. It is seen that rotor's optimum speed to obtain maximum power of it, is different in various wind speeds. Also, Fig. 2 shows that  $C_p$  is a function of  $\lambda$  and its maximum value is obtained for  $\lambda_{nom}$ .

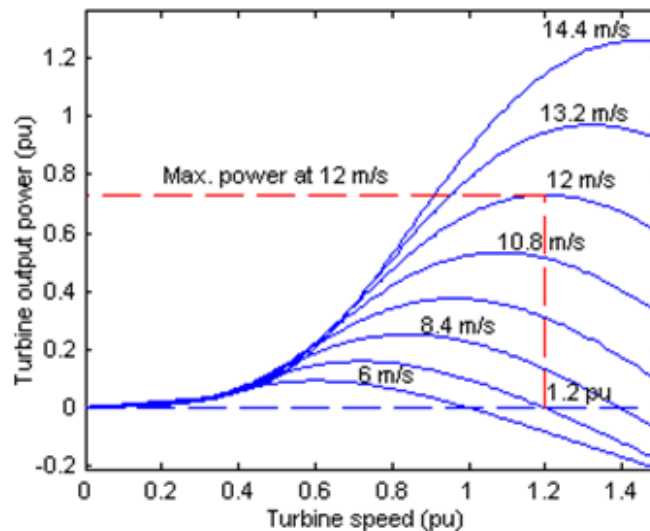

Fig. 3: Maximum power of turbine in term of wind and rotor speed.

So in order to obtain the maximum power of wind energy  $\lambda$  should always be fixed on the  $\lambda_{nom}$  value which is possible by blades properly designing. So relation (2) gives:

$$P_{M \max} = \frac{1}{2} \rho \pi R^2 C_{P \max} V_{WIND}^3 \quad (6)$$

The generator reference speed is calculated as follow:

$$\omega_M^* = \frac{\lambda_{nom}}{R} V_{WIND} \quad (7)$$

So by measuring wind speed, generator reference speed is obtained to get the maximum wind energy [7].

#### 4. Induction Generator:

In wind system, integrated and high degree models should be applied to simulate the induction generator in order to reach to the desired answer [8]. Several kinds of induction generators are studied in different sources [9]. In this paper 5th degree model is used for simulation and equations related to this model are obtained as follow by applying Park's conversion on machine voltage and current [9].

$$v_{qs} = R_s i_{qs} + \frac{1}{\omega_b} \frac{d\psi_{qs}}{dt} + \frac{\omega_e}{\omega_b} \psi_{ds} \quad (8)$$

$$v_0 = R_s i_{0s} + \frac{1}{\omega_b} \frac{d\psi_{0s}}{dt} \quad (9)$$

$$0 = R_r i_{dr} + \frac{1}{\omega_b} \frac{d\psi_{dr}}{dt} - \frac{(\omega_e - \omega_r)}{\omega_b} \psi_{qr} \quad (10)$$

$$0 = R_r i_{qr} + \frac{1}{\omega_b} \frac{d\psi_{qr}}{dt} + \frac{(\omega_e - \omega_r)}{\omega_b} \psi_{dr} \quad (11)$$

$$0 = R_r i_{0r} + \frac{1}{\omega_b} \frac{d\psi_{0r}}{dt} \quad (12)$$

where  $v_{ds}$ ,  $v_{qs}$ ,  $v_{0s}$ ,  $i_{ds}$ ,  $i_{qs}$ ,  $i_{0s}$  are stator voltages and currents and  $v_{dr}$ ,  $v_{qr}$ ,  $v_{0r}$ ,  $i_{dr}$ ,  $i_{qr}$ ,  $i_{0r}$  are rotor voltages and currents in d-q axis and:

$$\psi_{ds} = x_s i_{ds} + x_m i_{dr} \quad (13)$$

$$\psi_{qs} = x_s i_{qs} + x_m i_{qr} \quad (14)$$

$$\psi_{0s} = x_s i_{0s} \quad (15)$$

$$\psi_{dr} = x_r i_{dr} + x_m i_{ds} \quad (16)$$

$$\psi_{qr} = x_r i_{qr} + x_m i_{qs} \quad (17)$$

$$\psi_{0r} = x_r i_{0r} \quad (18)$$

where for balanced load  $i_{0s} = i_{0r} = 0$ .

The relation of torques applied to induction generator rotor is as follow:

$$T_m - T_e = J \frac{d\omega_r}{dt} + D\omega_r \tag{19}$$

where  $T_m$  is the mechanical torque applied to rotor and  $T_e$  is generator electrical torque and  $D\omega_r$  is damping torque and  $J$  is the sum of turbine and generator inertia. In reference [9] induction generator's electrical torque is shown as follow:

$$T_e = \frac{3}{2} \frac{P}{2\omega_b} x_m (i_{dr}i_{qs} - i_{qr}i_{ds}) \tag{20}$$

$$T_e = \frac{3}{2} \frac{P}{2\omega_b} (\psi_{qr}i_{dr} - \psi_{dr}i_{qr})$$

$$T_e = \frac{3P}{4} (\lambda_{qr}i_{dr} - \lambda_{dr}i_{qr})$$

where  $P$  is the number of induction generator's poles. Above relations express the dynamic of induction generator completely. Characteristics of generator used in simulation are presented in table 2.

**Table 2:** Induction generator parameters

Rated power	15 kW
Nominal voltage (L-L)	460 v
Rated frequency	60 Hz
number of Poles	4
Stator resistance $R_s$	0.2761Ω
Stator inductance $L_{ls}$	2.2 mH
Rotor resistance $R_r'$	0.1645Ω
Rotor inductance $L_{lr}'$	2.2 mH
Magnetizing inductance $L_m$	76.14 mH
Inertia $J$	kg.m <sup>2</sup> 0.1
Friction factor $F$	0.018 N.m.s

### 5. Control of Grid Connected System:

For a specific wind speed, wind turbine's operation point (output mechanical power and rotor speed) is determined by turbine's and load's (induction generator) characteristics junction point. The generator stator voltage is determined by grid voltage which will be used in induction generator simulation.

Machine equations are converted in the rotor flux frame. Rotor flux is turning in synchronous speed but in a different angle than stator flux, if there is a sinusoidal excitation. Choosing d-axis on the rotor flux, q component will be zero. This fact simplifies the equations very much. Now the torque and flux equations [9] expressed in previous part will be changed as follow:

$$\psi_{qr} = x_r i_{qr} + x_m i_{qs} = 0 \rightarrow i_{qr} = -\frac{x_m}{x_r} i_{qs} \tag{21}$$

$$T_e = -\frac{3P}{4} \lambda_{dr} i_{qr} = \frac{3P}{4} \frac{x_m}{x_r} \lambda_{dr} i_{qs} \tag{22}$$

$$\omega_r - \omega_e = \frac{x_m i_{qs}}{T_r \lambda_{dr}} \tag{23}$$

$$T_r = \frac{L_r}{R_r} \tag{24}$$

$$\lambda_{dr} = \frac{x_m}{1 + T_r \cdot p} \cdot i_{ds} \tag{25}$$

The above relations are the main relations of vector control [9], [10]. This method simplifies the induction machine controlling. This method is very similar to Dc machine's independent excitation where flux is the function of field current and torque is in proportion with flux and rotor current. The main problem of vector control method is flux axis angle calculation where is done by measuring the flux in two points with 90 degrees displacement and then angles are calculated using the resulted fluxes or estimating in regard to rotor speed [9].

**5.A. Generator Side Converter Control:**

Fig. 4 shows the generator side converter controlling system and structure. In this part, generator's speed is controlled to generate the maximum power. In order to reach this aim, a PI controller is used to control the speed. Speed controlling loop generates the current component of generator to control the torque and speed of generator for different wind speed values. Proportional and integrated PI controller values used in simulation are  $K_p = 12$  and  $K_i = 25$ . In respect to the fact that motor power is directly related to air gap flux, this air gap flux will be maintained in its nominal value and d-axis current value can be calculated by air gap flux on the basis of relation 25. Flux axis angle is calculated as:

$$\omega_r - \omega_e = \frac{x_m i_{qs}}{T_r \lambda_{dr}} \tag{26}$$

$$\theta = \int (\omega_r + \omega_m) dt \tag{27}$$

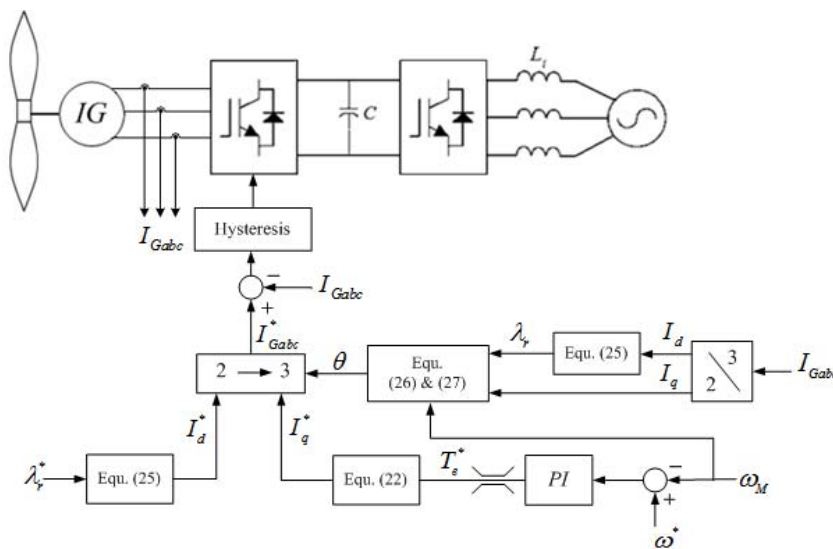

**Fig. 4:** Configuration and control system of generator side converter.

**5.B. Grid Side Converter Control:**

In Fig. 5 shows the grid side converter controlling system used to control the injective active and reactive powers. Relations of these powers in synchronous reference are as follow [10],[11]:

$$P = \frac{3}{2}(v_d i_d + v_q i_q) \tag{28}$$

$$Q = \frac{3}{2}(v_q i_d - v_d i_q) \tag{29}$$

If synchronous reference is synchronized with grid voltage, q-axis component of grid voltage would be zero and power relations will be as follow:

$$P = \frac{3}{2}v_d i_d \tag{30}$$

$$Q = -\frac{3}{2}v_d i_q \tag{31}$$

According to the above relations active and reactive powers are applied to control q-axis currents respectively. Two controlling loops are used to control these currents. Capacitor voltage controlling loop is used to control the d-axis reference power transfer. q-axis reference current is specified by selecting desired injected to grid reactive power. If unit power factor is considered q-axis reference current is regulate at zero value. In this simulation, integrated and proportional values are  $K_p=2$  and  $K_I=10$  for the PI controller which is controlling the capacitor voltage. PI controller which is controlling the currents is considered with  $K_p=0.1$  and  $K_I=80$  values.

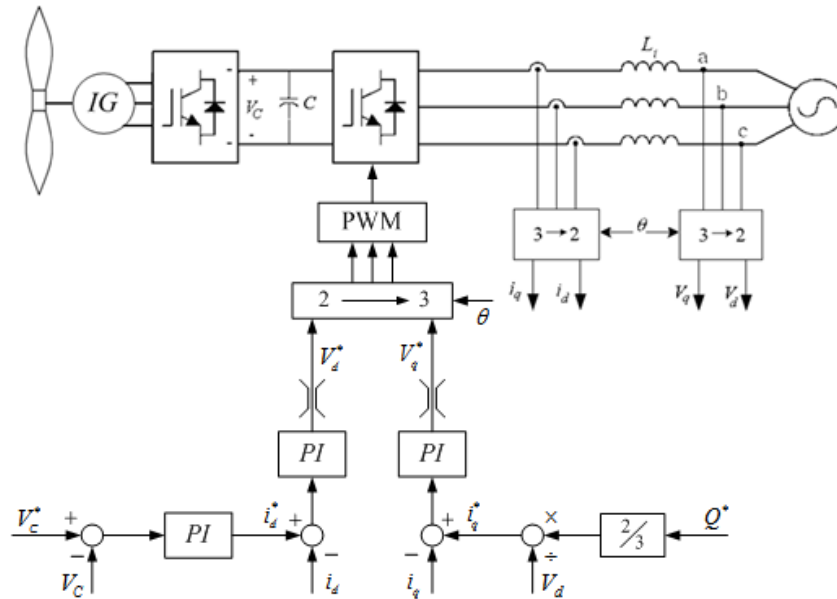
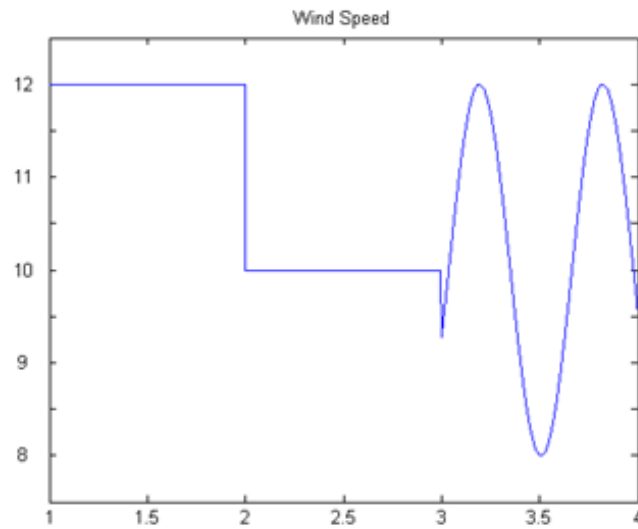

Fig. 5: Configuration and control system of grid side converter.

### RESULTS AND DISCUSSION

In order to study the proposed wind turbine system's operation, mentioned system is simulated by MATLAB/SIMULINK software with the parameters of tables 1 and 2.

Mentioned system is simulated for a wind with variable speed for 4 seconds. Fig. 6 shows the wind speed curve.



**Fig. 6:** Simulated wind speed (m/s).

In Fig. 7 and 8 capacitor voltages and injective reactive power are presented. These two figures show that the system has appropriately provided the requirements to be connected to grid. Because capacitor voltage value is maintained constant and the reactive power transferred to grid is negligible (unit power factor is considered).

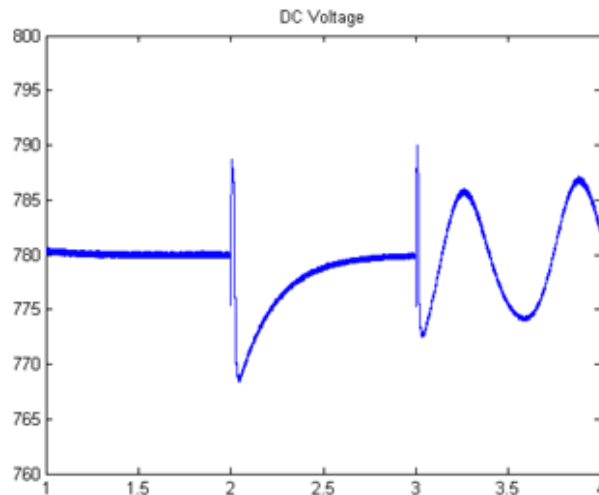

**Fig. 7:** DC link voltage (v).

Fig. 9 presents the true and estimated speeds of rotor. It is seen that rotor has tracked the calculated speed correctly to obtain the maximum power of turbine.

Fig. 10 shows the electrical and mechanical powers. It is seen that, injective power's curve tracks turbine's maximum mechanical power. The difference between these two curves is justified by considering mechanical and electrical losses.

**Conclusion:**

Developing wind turbines, different technologies are presented for them. Despite of vast application of doubly fed induction generators (DFIG), speed variation possibility in direct drive squirrel cage induction generator is more than that in DFIG. In this paper squirrel cage induction generator with two back to back voltage source converters is used to connect wind turbine to the grid. Generator side converter is controlled by indirect vector control method and the grid side converter is controlled by active and reactive powers injection to grid method. Simulation results show that the maximum power of turbine is obtained correctly for different wind speeds and also show that expected reactive and active powers are injected properly.



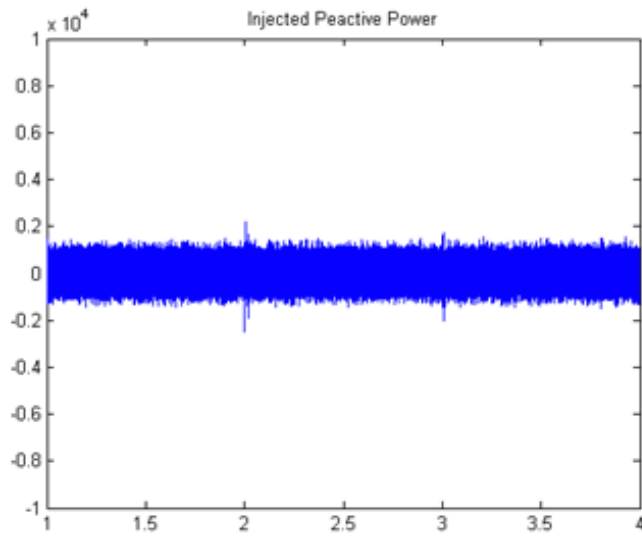

Fig. 8: Injected reactive power to grid (kVAr).

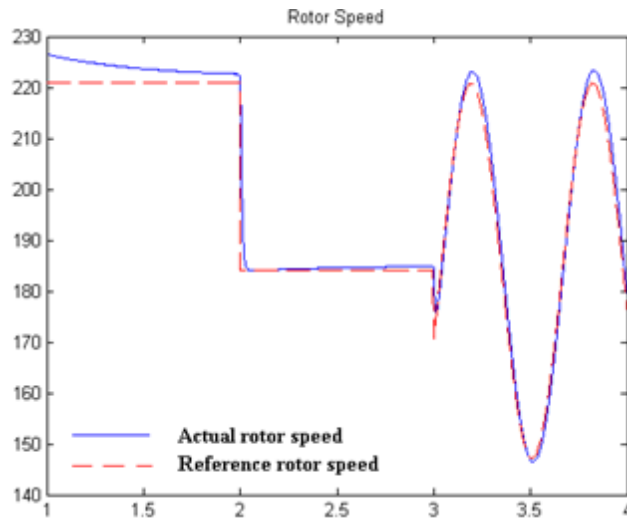

Fig. 9: Actual and reference rotor speed (m/s).

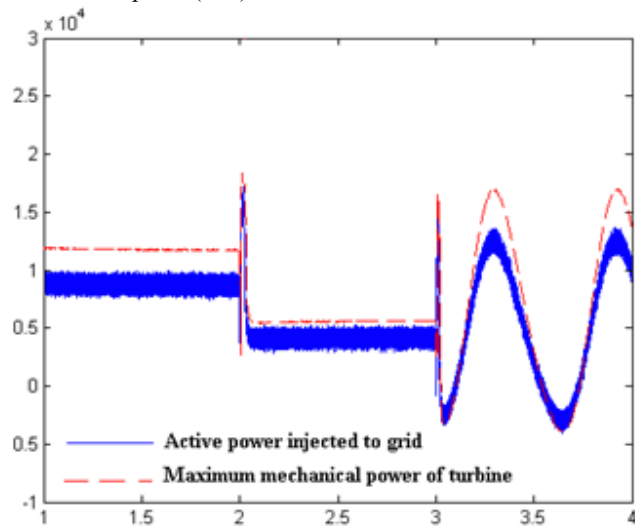

Fig. 8: Actual and reference rotor speed (kW).

## REFERENCES

- Abo-Khalil, A.G., H.G. Kim, D.C. Lee and J.K. Seok, 2004. Maximum output power control of wind generation system considering loss minimization of machines. IEEE 35th Annual Power Electron. Specialist Conference, 2: 1676-1681.
- Badrul, H. and C.S. Chellapilla, 2006. Double-fed induction generator control for variable speed wind power generation. *Elect. Power Syst. Res.*, 76: 786-800.
- Chinchilla, M., S. Arnaltes and J.C. Burgos, 2006. Control of permanent-magnet generators applied to variable-speed wind-energy systems connected to the grid. *IEEE. Trans. Energy Conversion*, 21 (1): 130-135.
- Hana, S.G., I.K. Yua and M. Park, 2007. PSCAD/EMTDC-based simulation of wind power generation system. *Renewable Energy*, 32: 105-117.
- Karrari, M., W. Rosehart and O.P. Malik, 2005. Comprehensive control strategy for a variable speed cage machine wind generation unit. *IEEE. Trans. Energy Conversion*, 20 (2): 415-423.
- Kim, S. and E. Kim, 2007. PSCAD/EMTDC-based modeling and analysis of a gearless variable speed wind turbine. *IEEE. Trans. Energy Conversion*, 22 (2): 421-430.
- Pena, R., R. Cardenas, R. Blasco, G. Asher and J. Clare, 2001. A cage induction generator using back to back PWM converters for variable speed grid connected wind energy system.
- Ong, C.M., 1997. *Dynamic Simulation of Electric Machinery, Using MATLAB and SIMULINK*. 1<sup>st</sup> Edn., Upper Saddle River: Prentice-Hall.
- Senjyu, T. and S. Tamaki *et al.*, 2006. Wind velocity and rotor position sensorless maximum power point tracking control for wind generation system. *Renewable Energy*, 31: 1764-1775.
- Surgevil, T. and E. Akpınar, 2005. Modelling of a 5-kW wind energy conversion system with induction generator and comparison with experimental results. *Renewable Energy*, 30: 913-929.
- Weisser, D. and R.S. Garcia, 2005. Instantaneous wind energy penetration in isolated electricity grids: concepts and review. *Renewable Energy*, 30: 1299-1308.