



ISSN:1991-8178

## Australian Journal of Basic and Applied Sciences

Journal home page: www.ajbasweb.com



### Fault Detection and Identification in Three Phase Transformer

<sup>1</sup>K.Deepa and <sup>2</sup>P.Vanaja Ranjan<sup>1</sup>Department of Electrical Engineering, Anna University, Guindy, Chennai<sup>2</sup>Department of Electrical Engineering, Anna University, Guindy, Chennai

#### ARTICLE INFO

##### Article history:

Received 3 October 2015

Accepted 31 October 2015

##### Keywords:

Flux Signature Analysis (FSA), Peak Variation Response (PVR).

#### ABSTRACT

The objective of this paper is to identify the winding faults in three phase transformer. A prototype model of the transformer has been designed and simulated using finite element method (FEM) based CAD package called Infolitica MagNet 6.11.2 in transient 2D solver. From the simulated results the peak variation response in flux linkage signature, flux density magnitude has been captured to identify the transformer winding faults. Then the faulty transformer result has been compared with simulated healthy transformer result. The design incorporated with external taps to create winding short circuit faults. The flux linkage simulation results are verified and validated with an experimental setup by the help of LabVIEW software.

© 2015 AENSI Publisher All rights reserved.

To Cite This Article: K.Deepa and P.Vanaja Ranjan., Fault Detection and Identification in Three Phase Transformer. *Aust. J. Basic & Appl. Sci.*, 9(33): 257-263, 2015

#### Abbreviations

<b>FRA</b>	Frequency Response Analysis
<b>DSO</b>	Digital Storage Oscilloscope
<b>CAD</b>	Computer Aided Design
<b>FEM</b>	Finite Element Method
<b>PVR</b>	Peak Variation Response

#### INTRODUCTION

The research focuses on diagnosing the three phase transformer inter turn winding fault and the transformer protection. In low voltage or high voltage transformers, the winding dislocation, winding deformation faults and the interturn winding insulation faults are preliminary faults and they occur due to the abnormal conditions like mechanical force on the winding, aging and over load. This inter-turn winding faults are engender heat in the faulty region of the winding and this heat causes the fault to grow rapidly to severe forms, such as coil- to- coil, phase-to-phase, phase-to-ground and phase to neutral fault. If the faults are not diagnoses at an early stage, which results in shutdown of power in consumer side and causes financial losses. Hence diagnoses of incipient faults like inter-turn fault is essential. In general the current, voltage, axial flux or temperature data are studied and analysed, the winding fault has been diagnosed and analysed by several techniques such as impedance matrix method and Frequency Response Analysis (FRA), Park vector Approach.

In this research to diagnose the three phase

transformer winding faults flux signature, flux pattern and flux density data are used with the help of National Instruments Lab View 2011 and Infolitica MagNet 6.11.2 (Makarand, S. Ballal, *et al.*, 2007).

#### Winding faults:

Once the inter turn faults occur, a large circulating fault current is induced in the short circuited turns, leading to localized thermal overloading in the defective winding portion. The generated heat in the defective region may enlarge the fault level as phase to phase fault or as phase to ground faults. Therefore, it would be advantageous to detect inter turn fault in its earliest stage to prevent further damage to the transformer thereby reducing repair costs and transformer outage time (Ozgonenel, O., *et al.*, 2007; Wang, H., K.L. Butler, 2002).

A suitable technique for diagnosing the transformer winding fault is the use of current data and flux data technique. To identify inter turn fault, coil to coil fault and phase to phase fault flux data is used in the form of flux pattern, flux signature and flux density magnitude. The prototype transformer

has been designed with taps on secondary windings to create above mentioned faults.

In this paper inter turn short circuit fault has been created in R phase within a single coil. The coil to coil short fault has been created within two coils of the R phase. Similarly the phase to phase short is

introduced across R phase and B phase. The above mentioned winding failures are implemented in the equivalent electrical circuit as shown in Figure 1 (Cardoso, A.J.M. and L.M.R. Oliveira, 1999). The primary and secondary winding is connected in  $\Delta/Y$ . The secondary side each phase carries 4 coils.

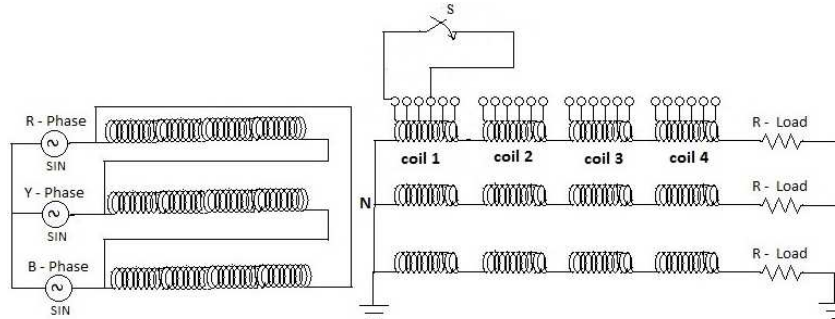
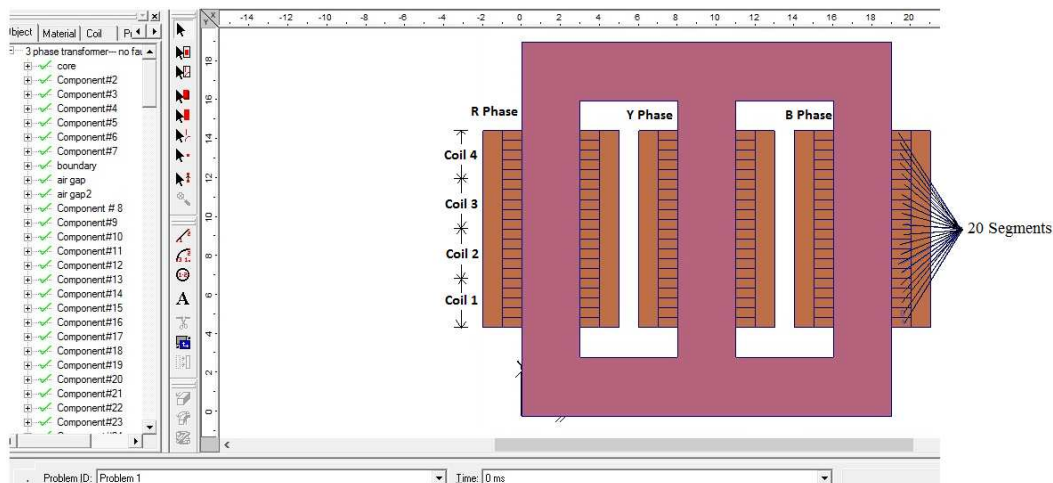

**Fig. 1:** Equivalent Electrical Circuit

The short circuit fault concept is designed by short circuiting the turns with switch S (Liu, S., *et al.*, 2007). Then flux linkages at the shorted portions has been captured and analyzed (Wang., H. and K.L. Butler, 2001; Kezunovic, M. and Y. Guo, 2000).

#### **Simulation model:**

The prototype transformer model is designed in finite element method (FEM) based CAD package called Infoliteca MagNet 6.11.2 and simulated using transient 2D solver is shown in Figure 2. The simulation stop time is 1000ms. The secondary winding each phase carries 4 coils and each coil having 5 segments. The soft pure iron material is used in transformer core.



**Fig. 2:** Prototype Transformer Diagram

## **RESULTS AND DISCUSSIONS**

The three phase transformer model has been analyzed at no-load under healthy and faulty condition by using transient 2D solver in MagNet 6.11.2. The transformer secondary winding has been subjected to various faults such as inter-turn short circuit, coil to coil short and phase-to-phase fault. When the switch is closed at 209ms, the fault is created. This fault has been reflected in the magnetic field strength and flux path of the transformer model.

The flux pattern and flux density magnitude has been captured at 209ms from the simulated model. The flux linkage signature has been captured directly from the simulation. Furthermore, it is analyzed in real time by integrating the collected secondary voltage data.

#### **Flux signature analysis:**

The flux signature analysis (FSA) has been done with flux data. It has been generated in the simulated prototype transformer model. It is a good method for

analyzing leakage flux level in the designed prototype transformer model at every milli second, and to identify the type of winding fault from the captured signature.

The flux signature analysis (FSA) has been done with flux data. It has been generated in the simulated

prototype transformer model. It is a good method for analyzing leakage flux level in the designed prototype transformer model at every milli second, and to identify the type of winding fault from the captured signature.'

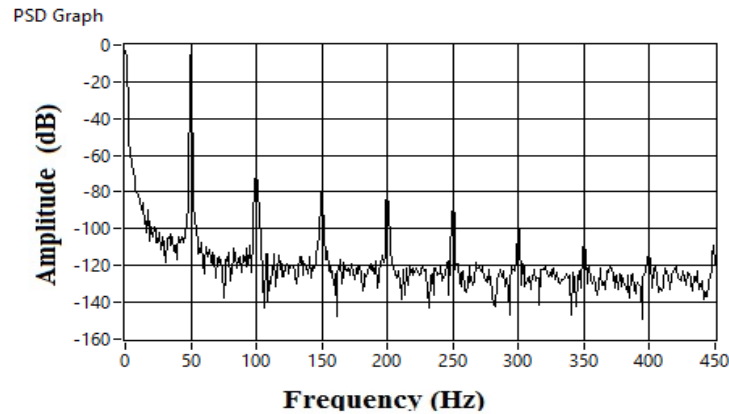

**Fig. 3:** Flux Linkage Peak Variation in Healthy Transformer at No Load

In healthy transformer, the peaks occur at odd and even order harmonics (i.e. 1st, 2nd, 3rd, 4th, 5th, 6th, 7<sup>th</sup> .... etc). The peak variation responses are -

3dB, -72dB, -80dB, -85dB, -90dB, -100dB, -110dB respectively. All peak variations are clearly visible in the graph. It is shown in Figure 3.

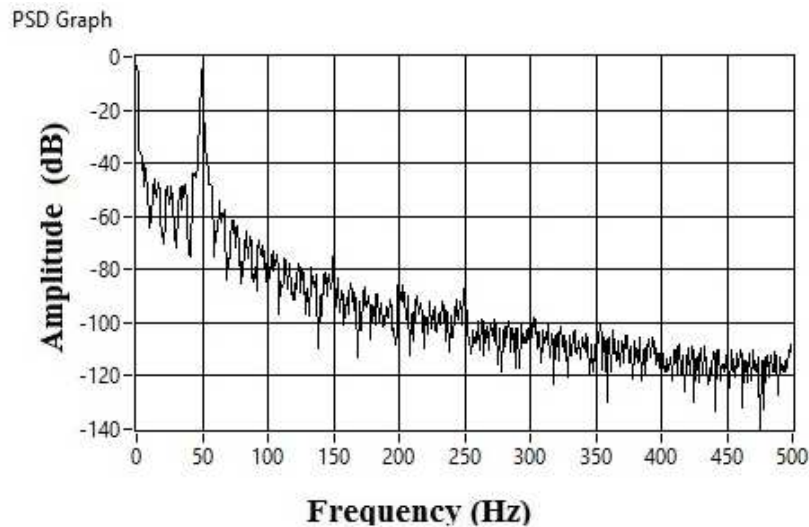

**Fig. 4:** Flux Linkage Peak Variation in Inter-Turn Short at No Load

In an inter turn short circuit fault, the peak variation response at 50Hz is -5dB. There is no response in 100Hz. The response at 150Hz, 200Hz and 250Hz frequencies are -75dB, -85dB and -85dB

amplitude respectively. But it is not visible clearly. The spectral distribution is started at -5 dB. In the waveform, there are more visible peaks from 0 to 100Hz. It is shown in Figure 4.

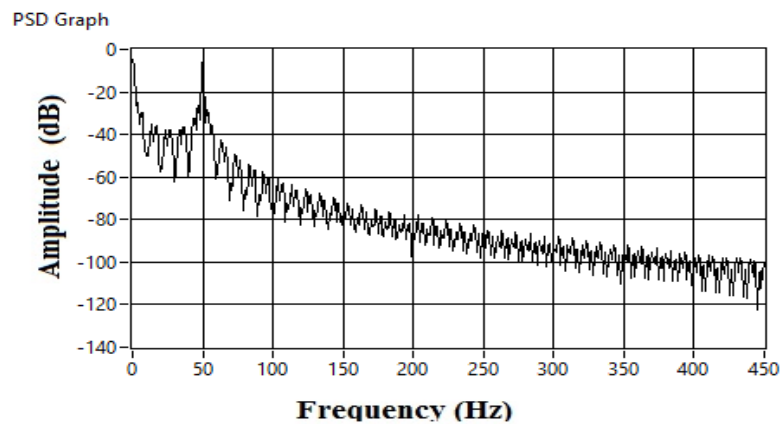

**Fig. 5:** Flux Linkage Peak Variation in Coil to Coil Short at No Load

In the coil to coil short circuit fault model the peak variation response at fundamental frequency (50Hz) is -3 dB. The spectral distribution is started at -5 dB. The peak variation responses at remaining

frequencies are suppressed compared with healthy transformer. The coil to coil short circuit fault result is shown in Figure 5.

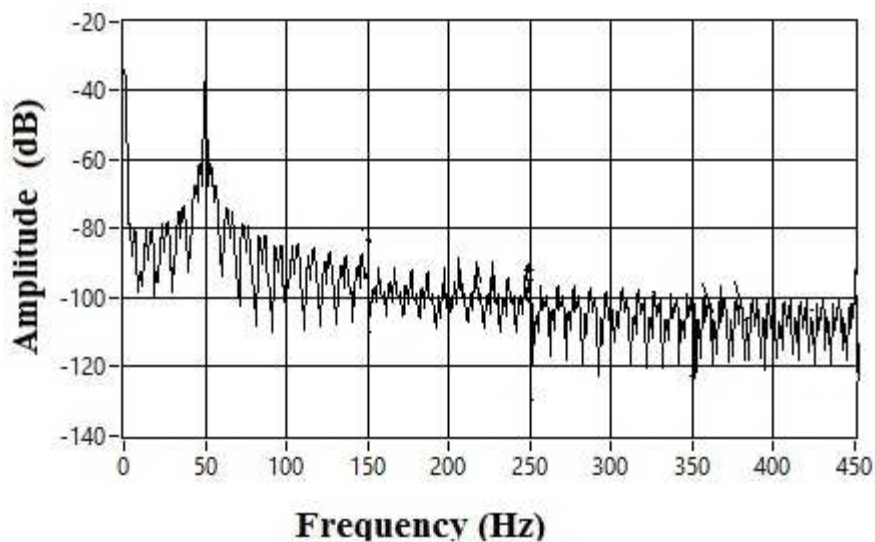

**Fig. 6:** Flux Linkage Peak Variation in phase to Phase Short at No Load

In the phase to phase short circuit fault model the peak variation response at fundamental frequency (50Hz) is -39 dB. The power spectral distribution is disturbed in remaining frequencies. The spectral distribution is started at -38 dB. In phase to phase fault the spectral is distributed in wide area. It is shown in Figure 6.

#### **Flux Density Magnitude Monitoring:**

This topic also discusses flux density magnitude monitoring technique. In this technique the flux density magnitude has been measured at various types of faults under no load condition. The flux density magnitude will be increased when the short

circuit fault severity increases. One more monitoring method also discussed in this topic. i.e., the flux density magnitude has been measured at various types of faults under no load. The flux density magnitude will be increased when short circuit fault severity increased. At faulty conditions some of the secondary current circulated in the short circuited part, which may cause heat effect. This abnormal case draws more current from the supply. Therefore flux level also increases (Ramalakshmi, G., L. Kalaivani and R. Madavan, 2010). The flux density magnitude is monitored at short circuit instant. The short circuit has created at 209ms.

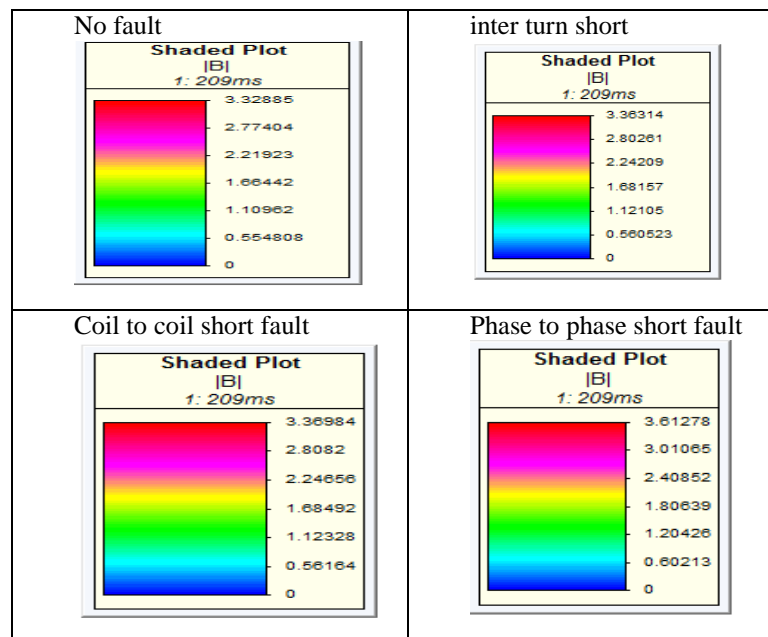

**Fig. 7:** Flux Density Magnitude at Various Fault Conditions under No Load

The highest value of the flux density magnitude for healthy as well as inter turn short circuit winding fault, coil to coil short circuit winding fault and

phase to phase short fault has been noted from the Figure 7 and it is listed in the table 1.

**Table 1:** Flux density magnitude

Machine conditions	Flux density magnitude
Healthy model	3.32885
Inter turn short circuit fault	3.36314
coil to coil short	3.36984
phase to phase short	3.61278

#### Hardware implementation:

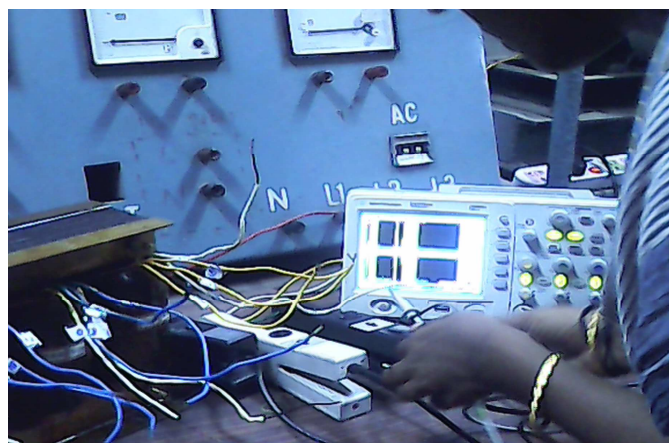

**Fig. 12:** Hardware implementation test bed

The three phase transformer test bed shown in Figure 12. Among the three techniques i.e. the peak variation response in flux linkage signature, flux density magnitude and flux pattern variation the flux linkage signature technique is only used in real time approach. The test bed contains three phase transformer,

DSO, voltage probes and PC. The voltage data is collected from the voltage probe. In real time analysis the spectral analysis is done with data obtained with the voltage integrated to obtain flux linkage variations during faults as data since practically the flux linkage is difficult to measure.

$E = d\lambda/dt$   
 $\lambda = \int E dt$  variations in spectral response.

The LabVIEW software is used to integrate the voltage data. Then the integrated data is analyzed.

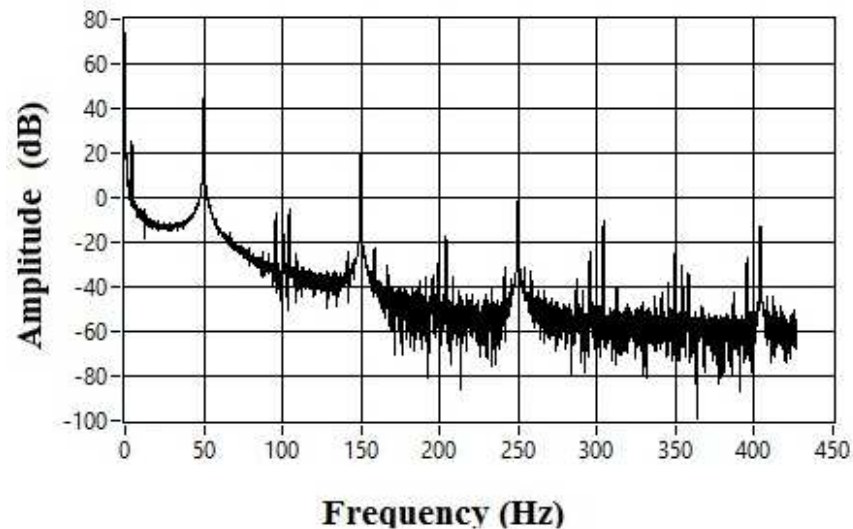

**Fig. 13:** Flux Linkage Peak Variation in healthy transformer at no load

In healthy transformer, the peaks clearly occurring at both odd and even order harmonics frequency (1st, 2nd, 3rd, 4th, 5th, 6th, 7<sup>th</sup> etc). The peak variation responses are 45dB, -18dB, 20dB, -

30dB, 0dB respectively. The spectral is started at 25 dB spectral magnitudes. In the waveform, there is no huge visible peak from 0 to 100Hz. It is shown in Figure 13.

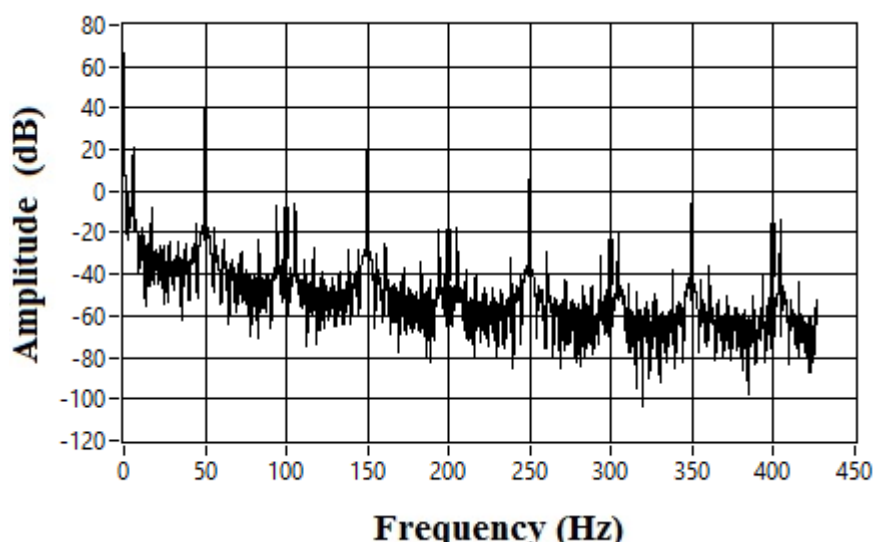

**Fig. 14:** Flux Linkage Peak Variation in Inter Turn short at no load

In inter-turn short circuit fault transformer model, the peaks occurring at both odd and even order harmonics frequency (1st, 2nd, 3rd, 4th, 5th, 6th, 7<sup>th</sup> etc). The peak variation responses are 40dB, -10dB, 20dB, -20dB, 5dB, -25dB, -5dB, -15dB respectively. The spectral is started at 25 dB spectral magnitudes. In this waveform, there is a huge visible peak from 0 to 100Hz. It is shown in Figure 14.

#### **Conclusion:**

The winding fault detection in three phase transformer using flux Signature Analysis (FSA),

flux density magnitude analysis is proposed. A prototype model of the transformer has been designed to study the winding faults through simulation. Simulation has been carried out using Magnet 6.11.2. The emulated winding faults are inter-turn, coil to coil and phase-to-phase. In FSA method the flux linkage signature, the flux lines variation and in flux density analysis flux density magnitudes are observed. Experimentally the inter-turn short circuit fault has observed using FSA. The three phase transformer condition has been monitored using Lab VIEW software

## REFERENCES

- Makarand, S. Ballal, Zafar J. Khan, Hiralal M. Suryawanshi, and Ram L. Sonolikar, 2007. "Adaptive Neural Fuzzy Inference System for the Detection of Inter-Turn Insulation and Bearing Wear Faults in Induction Motor", IEEE Trans. on industrial electronics, 54(1): 250-258.
- Ozgonenel, O., D.W.P. Thomas, C. Christopoulos, 2007. 'TLM modeling of transformer with internal short circuit faults', COMPEL: Int. J. Comput. Math. Electr. Electron. Eng., 26(5): 1304-1323.
- Wang, H., K.L. Butler, 2002. 'Modeling transformers with internal incipient faults', IEEE Trans. Power Deliv., 17(2): 500-509.
- Cardoso, A.J.M. and L.M.R. Oliveira, 1999. "Condition monitoring and diagnostics of power transformers", Int. J. COMADEM, 2(3): 5-11.
- Liu, S., Z. Liu and O.A. Mohammed, 2007." FE-Based Modeling of Single-Phase Distribution Transformers with Winding Short Circuit Faults", IEEE Transactions on Magnetics, 43: 4.
- Wang,, H. and K.L. Butler, 2001. "Finite element analysis of internal winding faults in distribution transformers," IEEE Trans. Power Del., 16(3): 422-428.
- Kezunovic, M. and Y. Guo, 2000. "Modeling and simulation of the power transformer faults and related protective relay behavior," IEEE Trans. Power Del., 15(1): 44-50.
- Tang, W.H., A. Shintemirov, Q.H. Wu, 2010. 'Detection of Minor Winding Deformation Fault in High Frequency Range for Power Transformer', IEEE.
- Ramalakshmi, G., L. Kalaivani and R. Madavan, 2010. "Computation of Electromagnetic Forces in Transformer Winding under Short Circuit Currents", International Journal of Advanced Engineering Applications, 2(4): 30-36.
- Peter Palmer-Buckle, Karen L. Butler and N.D.R. Sara., 1999. "Characteristics of Transformer Parameters During Internal Winding Faults Based On Experimental Measurements", IEEE.
- Deepa, K., P. Vanaja Ranjan, S. Deepa, 2013. "Diagnosis of Stator Winding Short Circuit Fault in Three Phase squirrel cage Induction Machine", International Review on Modelling and Simulations(I.RE.MO.S.), 6(6): 1884-1890.
- Amine Yazidi, Member, IEEE, Humberto Henao, 2011. "A Web-Based Remote Laboratory for Monitoring and Diagnosis of AC Electrical Machines" IEEE transactions on industrial electronics, 58: 10.
- Rajamani, P and Sivaji Chakravorti, 2012. Identification of Simultaneously Occurring Dynamic Disc-to-disc Insulation Failures in Transformer Winding under Impulse Excitation", IEEE Trans on Dielectrics and Electrical Insulation, 19: 2.
- Kumbhar, G.B. and S.V. Kulkarni, 2007. 'Analysis of Short-Circuit Performance of Split-Winding Transformer Using Coupled Field-Circuit Approach' IEEE Trans on power delivery, 22(2): 936-943.
- Shantanav Bhowmick, 2010.'Detection of Inter-turn Winding Fault in Single-phase Transformers Using a Terminal Measurement Based Modeling Technique', Master of Applied Science thesis, West Bengal University of Technology, India.