

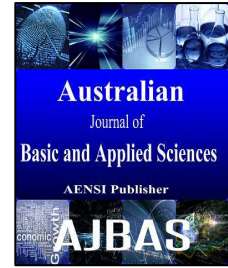

## AUSTRALIAN JOURNAL OF BASIC AND APPLIED SCIENCES

ISSN:1991-8178 EISSN: 2309-8414  
Journal home page: www.ajbasweb.com



# Performance Evaluation of Negative Output Multiple Lift-Push-Pull Switched Capacitor Luo Converter

<sup>1</sup>Srinivasan and <sup>2</sup>Sivakumaran T. S

<sup>1</sup>Research Scholar, Department of EEE, Bharath University, Chennai, Tamil Nadu, India.

<sup>2</sup>Dean PG Studies, Department of EEE, Arunai College of Engineering, Tiruvannamalai, Tamil Nadu, India.

### Address For Correspondence:

Srinivasan, Research Scholar, Department of EEE, Bharath University, Chennai, Tamil Nadu, India

### ARTICLE INFO

#### Article history:

Received 26 April 2016

Accepted 21 July 2016

Published 30 July 2016

#### Keywords:

DC-DC Converter; Luo Converter; PI controller.

### ABSTRACT

The micro-power-consumption technique requires high power density DC/ DC converters and power supply sources. The voltage lift technique is a popular application in electronic circuit design. The power converter performs DC-DC step-up voltage conversion with high efficiency, high power density and cheap topology in a simple structure. The objective of this work is to develop PI controller for Elementary circuit of N/O push-pull switched capacitor Luo converters to ensure constant load voltage under supply and load disturbances using MATLAB/Simulink software. The simulation results are presented and evaluated.

## INTRODUCTION

Recently DC-DC conversion technique has developed in recent years, since it is required to reach a high power density, high-voltage transfer gain and high power efficiency. Double-output DC-DC converters convert the positive input source voltage to positive and negative output voltages. They consist of two conversion paths, one is positive conversion path and the other is a negative conversion path. These mirror symmetrical double-output voltages are especially required in industrial applications and computer periphery circuits such as operational amplifiers, computer periphery power supplies, differential servo motor drives and some symmetrical voltage medical equipment's. To regulate the output voltage of DC-DC converters irrespective of load variations and supply disturbances, it is necessary to operate the DC-DC converters as closed loop systems.

With pulse-width modulation control, the regulation of output voltage of DC-DC converters are achieved by varying the duty cycle of the electronic switch keeping the frequency of operation constant (F. L. Luo, 1999, F. L. Luo, 1998, F. L. Luo, 1999, F.L. Luo, 2000, S. P. Natarajan, 2013). These converters in general have complex non-linear models with parameter variation problems. PI controller is used in this work for regulating the output voltage of reverse self-lift negative output Luo converters under supply and load disturbances. Tests for load regulation and line regulation are carried out to evaluate the controllers' performances. The results are presented and evaluated.

### Negative Output Multiple Lift Push-Pull Switched Capacitor Luo Converter:

Since the switched-capacitor can be integrated into the power integrated circuit (IC) chip, its size is small. Combining the switched-capacitor and voltage lift technique create a DC/ DC converter with small size, high power density, high voltage transfers gain, high power efficiency, and low EMI. Switched-capacitor (SC) converters can perform in push-pull state with conduction duty cycle  $k = 0.5$ . Each circuit has one main switch  $S$  and several slave switches as  $S_i$  ( $i = 1, 2, 3 \dots n$ ). The number  $n$  is called stage number. The main switch  $S$  is on

### Open Access Journal

Published BY AENSI Publication

© 2016 AENSI Publisher All rights reserved

This work is licensed under the Creative Commons Attribution International License (CC BY).

<http://creativecommons.org/licenses/by/4.0/>



Open Access

To Cite This Article: Srinivasan and Sivakumaran T. S., Performance Evaluation of Negative Output Multiple Lift-Push-Pull Switched Capacitor Luo Converter. *Aust. J. Basic & Appl. Sci.*, 10(12): 126-130, 2016

and slaves off during switch-on period  $kT$ , and  $S$  is off and slaves on during switch-off period  $(1 - k)T$ . The load is resistive load  $R$ . Input voltage and current are  $V_{in}$  and  $I_{in}$ , output voltage and current are  $V_o$  and  $I_o$ .

### Switching Operation:

The elementary circuit and its equivalent circuits during switch-on and switch-off are shown in Fig.1.

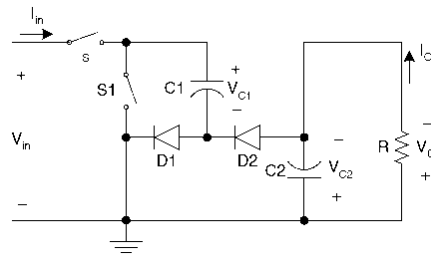

(a) Circuit diagram

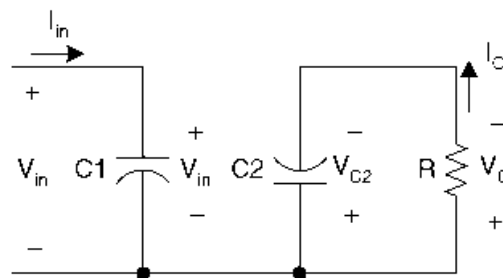

(b) Equivalent circuit during S on

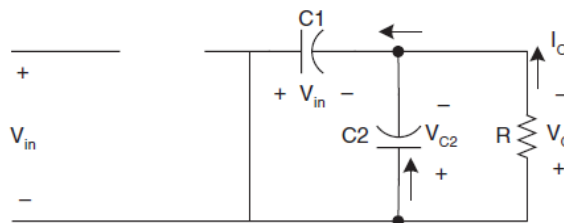

(c) Equivalent circuit during S1 on

**Fig. 1:** Negative output multiple lift-push-pull switched capacitor Luo converter Elementary circuit and its equivalent circuits during switch-on and switch-off

Two switches  $S$  and  $S_1$  operate in push pull state (Chung et.al 2000, Gao and Luo, 2001, Harris and Ngo, 1997, Liu and Chen, 1998 and Luo and Ye, 2002). The voltage across capacitor  $C1$  is charged to  $V_{in}$  during switch on. The voltage across capacitor  $C2$  is charged to  $V_o = 2V_{in}$  during switch off. Therefore, the output voltage is,

$$V_o = 2V_{in} \quad (1)$$

Considering the voltage drops across the diodes and switches, we combine all values in a figure of  $\Delta V_1$ . The real output voltage is

$$\begin{aligned} V_o &= 2V_{in} - \Delta V_1 \\ &= 2V_{in} - (V_{D1} + V_s + V_{S1} + V_{D2}) \\ &= 2V_{in} - (2V_s + 2V_d) \end{aligned} \quad (2)$$

### PI Controller:

PI controllers have been used for several decades in industries for process control applications. The reason for their wide popularity lies in the simplicity of design and good performance including low percentage overshoot and small settling time for slow process plants. The most appreciated feature of the PI controllers is

their relative easiness of use, because the three involved parameters have a clear physical meaning. This makes their tuning possible for the operators also by trial and error and in any case a large number of tuning rules have been developed.

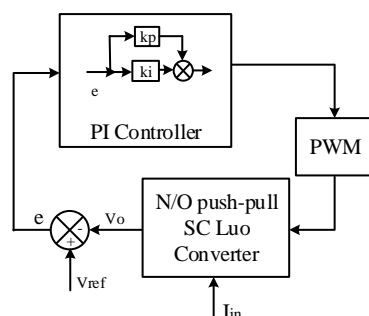

**Fig. 2:** Structure of PI controller

Although all the existing techniques for the PI controller parameter tuning perform well, a continuous and an intensive research work is still underway towards system control quality enhancement and performance improvements. A PI controller is essentially a generic closed loop feedback mechanism. In working principle is that it monitors the error between a measured process variable and a desired set point; from this error, a corrective signal is computed and is eventually feedback to the input side to adjust the process accordingly. The differential equation for the PI controller is as follows,

$$u(t) = K_p e(t) + T_i \int_0^t e_p(t) dt \quad (3)$$

Thus, the PID controller algorithm is described by a weighted sum of the three times functions were the three distinct weights are: KP (Proportional gain) determines the influence of the present error value on the control mechanism, I (integral gain) decides the reaction based on the area under the error time curve up to the present point accounts for the extent of the reaction to the rate of change of the error with time (Astrom and Hagglund, 1994). The structure of PI controller is shown in Fig.2.

### Simulation Results:

Fig.3 shows the closed loop Simulink diagram of Elementary Circuit of N/O Push-Pull SC Luo Converter. The proposed system analysis has been done with R load. The circuit specifications are shown in Table 1.

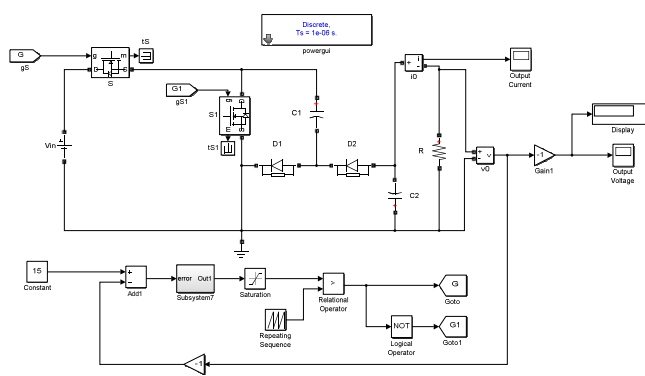

**Fig. 3:** Closed Loop Simulink of Elementary Circuit of N/O Push-Pull SC Luo Converter

**Table I:** Specification of circuit parameters

Parameters	Specification
Input voltage	12V
Output voltage	15 V
Load resistance	100 Ω
Switching frequency	20KHZ
Capacitance (C & C <sub>1</sub> )	100 μF
Duty range	0.05 to 0.95

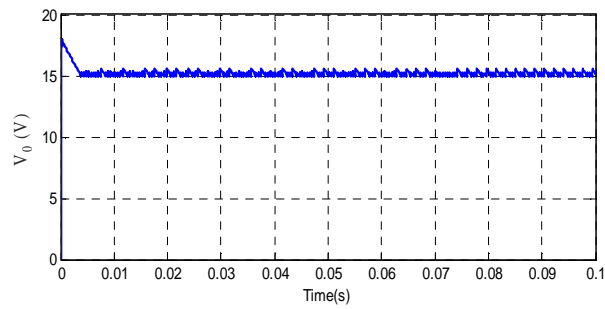

**Fig. 4:** Simulated start-up of the output voltage of Negative output multiple lift-push-pull switched capacitor Luo converter with set point 15V and nominal load 100Ω

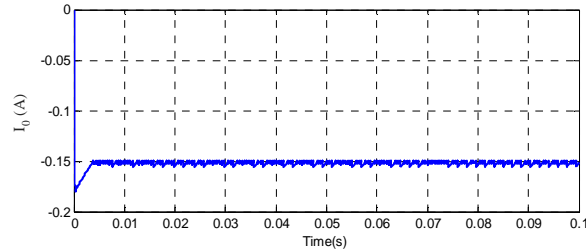

**Fig. 5:** Simulated start-up of the output current of Negative output multiple lift-push-pull switched capacitor Luo converter with set point 15V and nominal load 100Ω

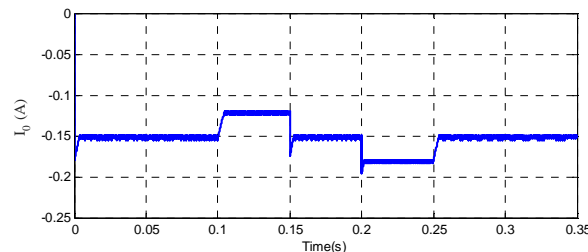
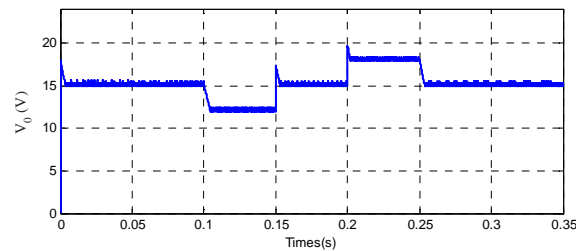

**Fig. 6:** Simulated output voltage and current of Negative output multiple lift-push-pull switched capacitor Luo converter with sudden line disturbances and servo responses (15V-12V-15V-18V-15V)

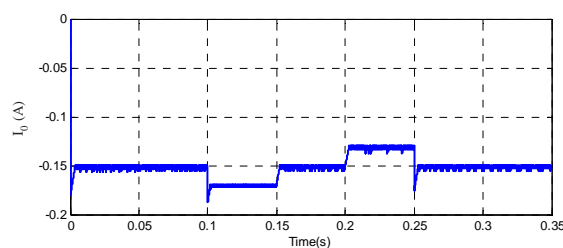
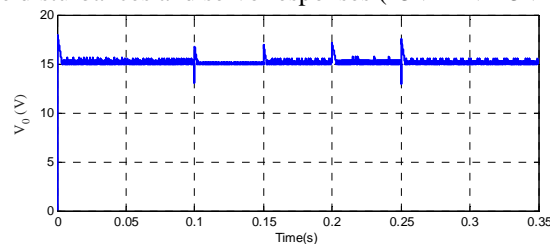

**Fig. 7:** Simulated output voltage and current of Negative output multiple lift-push-pull switched capacitor Luo converter with sudden load disturbances and regulatory responses (100Ω-90Ω V-100Ω -110Ω -100Ω)

Fig.4 shows the closed loop response of start-up of the output voltage and current waveform of Elementary Circuit of N/O Push-Pull SC Luo converter with set point 15V and nominal load 100Ω with PI controller. Fig.5 shows the simulated output voltage and current waveform of Elementary Circuit of N/O Push-Pull SC Luo converter with sudden line disturbances due to supply disturbances and servo responses. Figure shows the response with increment and decrement of 33% supply disturbances. Fig.7 shows the simulated output voltage and current waveform of Elementary Circuit of N/O Push-Pull SC Luo converter with sudden load disturbances. The Figure shows the response with increment and decrement of 10% load.

### **Conclusions:**

The Simulation results show that the proposed PI controller regulates satisfactorily the output voltage of Elementary Circuit of N/O Push-Pull SC Luo Converter irrespective of line and load disturbances. It also overcomes the effects of parasitic elements and increases the output voltage of the DC-DC converters, introducing the characteristics of high efficiency, high power density and cheap topology and near zero output voltage and current ripples. These converters can be used in computer periphery circuits, medical equipment and industrial applications with high output voltages. Further, in the future the conventional PI controller may replace by an intelligent controller to determine the performance of the proposed scheme.

### **REFERENCES**

- Astrom, K and T. Hagglund, 1994. PID Controller: Theory, Design and Tuning, 2nd edition, Library of Congress Cataloging-in-Publication Data, pp: 120-134.
- Chung, H.S., S.Y.R. Hui, S.C. Tang and A. Wu, 2000. On the use of current control scheme for switched-capacitor DC/DC converters, *IEEE Trans. Ind. Electron*, 47: 238.
- Gao, Y. and F.L. Luo, 2001. Theoretical analysis on performance of a 5V/12V push-pull switched capacitor DC/DC converter, in *Proceedings of IEE-IPEC'2001*, Singapore, p: 711.
- Harris, W.S. and K.D.T. Ngo, 1997. Power switched-capacitor DC-DC converter: analysis and design, *IEEE Transactions on ANES*, 33: 386.
- Joseph Basanth, A., S.P. Natarajan and T.S. Sivakumaran, 2009. Development of FLC for ZCS LUO QRC. International conference PESA-09, Hong Kong.
- Joseph Basanth, A., S.P. Natarajan and T.S. Sivakumaran, 2013. Performance analysis of positive output super-lift re-lift Luo converter With PI and neuro controllers. *IOSR Journal of Electrical and Electronics Engineering (IOSR-JEEE)*. 6(3): 21-27.
- Liu, J. and Z. Chen, 1998. A push-pull switched capacitor DC-DC set-up converter, *Technology of Electrical Engineering*, 1(41).
- Luo, F.L. and H. Ye, 2002. Positive output multiple-lift push-pull switched-capacitor Luo converters, in *Proceedings of IEEE-PESC'2002*, Cairns Australia, p: 415.
- Luo, F.L., 1998. Re-Lift converters: Design, test, simulation and stability analysis. *IEE-EPA Proceedings*. 145(4): 315-325.
- Luo, F.L., 1999. Double output Luo converters" *Proceedings of the IEEE international conference IPEC'99*, Singapore.
- Luo, F.L., 1999. Positive output Luo converters: voltage lift technique. *IEE-EPA Proceedings*. 146(4): 415-432.
- Luo, F.L., 2000. Double-output Luo converters, an advanced voltage-lift technique. *Electric Power Applications, IEE Proceedings*. 147(6): 469-485.